

# Waters Lighting | Lanterns

Small Cotleigh

Ref: S.C.50/100W/240/230V



- This lantern is modelled on the original gas lit lantern of the 1920s style period. (Shown on 180° tube bend bracket for post top mounting.)
- Stirrup mounting bracket or ceiling pendant optional.
- Constructed from spun aluminium with polyester stove enamel finish. (other colours available on request)
- Fitted with H.P.S / Metal Halide control gear or standard E/S lampholder.

Refer to specification sheet for full technical details

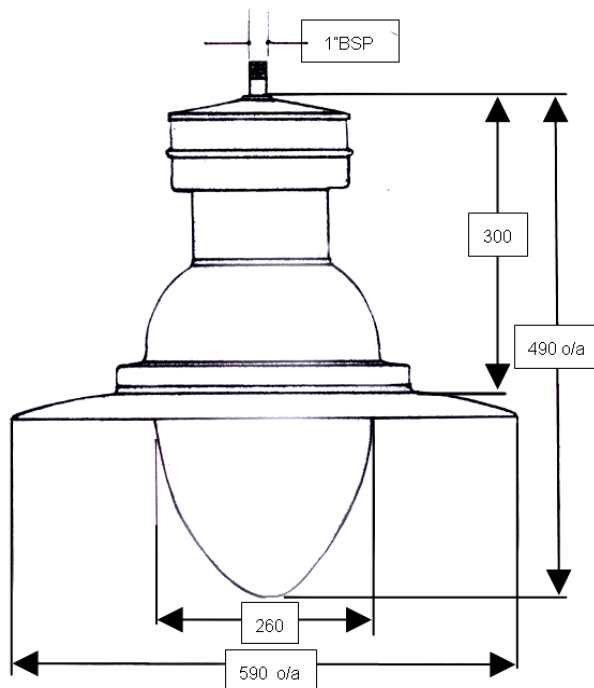

All dimensions are in mm and are approx.